

HIGH PERFORMANCE, ECONOMICAL HEAVY DUTY PUNCHING, PARTING & NOTCHING TOOLS

GTM Tool

Features Through The
Tool Lubrication

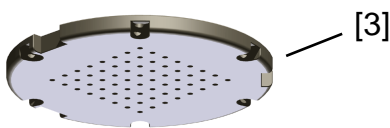
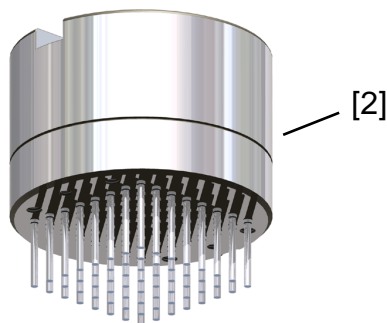
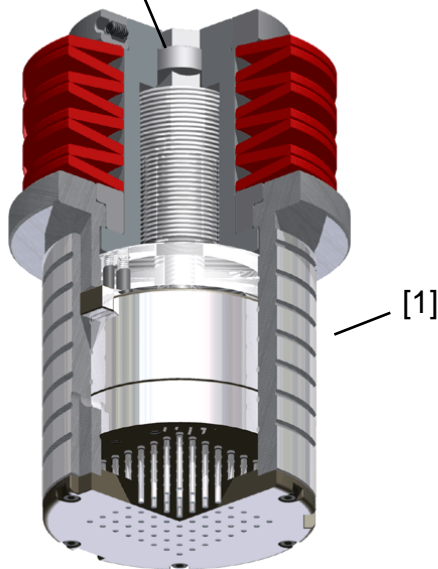

'D' Station
PUSH BUTTON ADJUSTABLE
Features Through-The-Tool Lubrication
NO SHIMS REQUIRED Up to 10mm Adjustment

[1] Guide AssemblyAA860HD-000
(does not include punch & stripper plate)

GUIDE COMPONENTS

- Guide BodyAA860HD-001
- Adjustable Punch Driver SpigotAA860-002
- Spring Housing Spigot.....AA860-003
- Spring Retaining Ring.....AA860-004
- Spring Retaining HeadAA860-005
- Disc Spring (ea)AA1052-000
- T' Handle.....AA962-000

TOOLING

- Punch, Die & Stripper Set (as ordered)...AA700HD-XXX
- [2] Punch (as ordered).....AA701-XXX
- [3] Stripper Plate (as ordered)AA752-XXX
- Die (as ordered)AA703-XXX

PARTING TOOLS (refer to 'C','D','E'
Station Parting Tool Systems)

NOTCHING

(Stock Size 50 x 50mm)

- [4] Punch (Shear Proof).....AA701-200S
- Stripper.....AA752-200

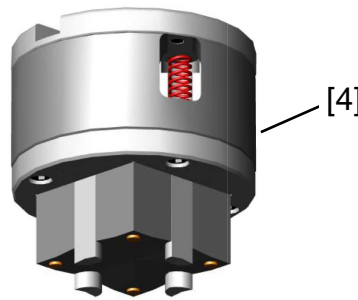

GLOBAL TOOLS & MACHINES

Email: sales@globaltools.com.au

M: 0409 324 178

Web: www.globaltools.com.au